

Slip resistant surface on steps and bottom of tank

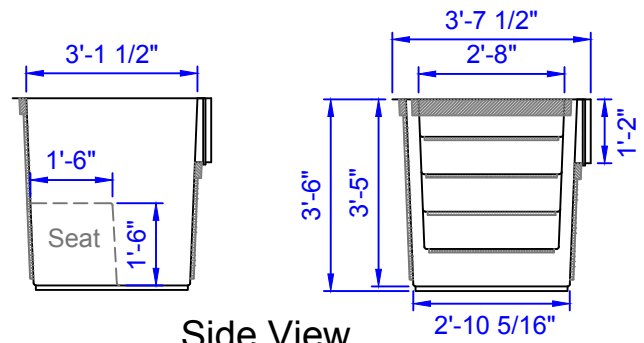

**Baptistery Data**  
 Overall Width = 3'-7 1/2"  
 Overall Length = 8'-5"  
 Overall Height = 3'-6"  
 Overall Depth = 3'-5"  
 Unit Weight = 350 lbs.  
 Water Capacity = 400 Gallons  
 Recommended Heater:  
 PBH 5500 Heater System  
 Optional Heater:  
 PBH 11000 Heater System  
**Available Colors**  
 Blue   
 White   
 Aqua   
 Beige   
 Note: Color samples available at customers request



33 Lewittes Rd.  
 Taylorsville, NC 28681  
 Phone: 828-632-8883  
 Fax: 828-632-5585  
 www.piedmontcomposites.com

Scale: NA  
 Drawn by: TJD/JEM  
 Created On: 8/16/02  
 Updated On: 03/27/19

**DRY-MINISTER**  
 Model: **8-LE-WINDOW**

Note: All drawings are the property of Piedmont Composites & Tooling, LLC. Variation in material thickness, dimension and weight may occur. PCT reserves the right to change or modify design at anytime without notice.